

# Quasar Baby

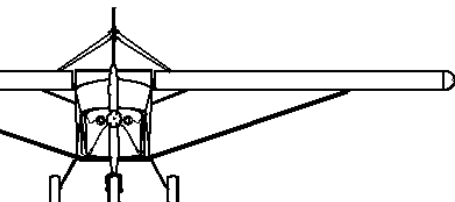

Quasar Baby is the brand new design from AeroAlcool Tecnologia Ltda. With a whole different design from its “brother-plane”, the Quasar Lite, this plane was designed for the low-cost market. It is all made of metal materials, combining to the best aluminum and steel to produce a light and strong airframe.

It is a high wing, two place, single engine, tricycle airplane with conventional tail.



This plane follows all the standards of a LSA airplane and when available will be LSA certified.

Will be available in two versions: Ready to fly and kit.

It is powered by the reliable HKS 700, 60hp, engine.

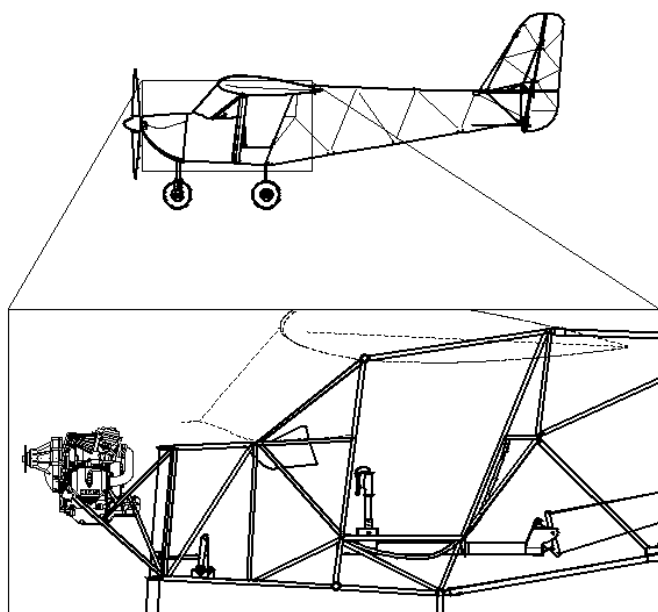
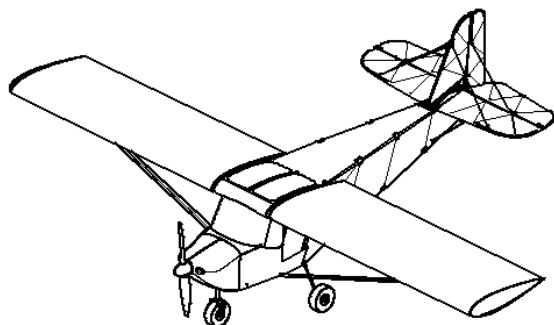

Dimensions and areas		
Wingspan	32,84 ft	10,01 m
Lenght	21,12 ft	6,44 m
Height	9,31 ft	2,84 m
Cabin max width	3,64 ft	1,11 m
Wing area	161,6 ft <sup>2</sup>	15,01 m <sup>2</sup>
Weights and loads		
Max Takeoff weight	930 lb	420 kg
Max Fuel Weight	123 lb	56 kg
Empty Weight	397 lb	180 kg
Wing loading	5,75 lb/ft <sup>2</sup>	28 kg/m <sup>2</sup>
Performance (ISA condition)		
Stall speed	34 mph	54 km/h
Cruise Speed	80 - 85 mph	128-136 km/h
Climb rate	1050 ft/min	5,3 m/s
Range	640 miles	1000 km
Endurance		8 hours
L/D		11:1
Take off distance	280 ft	85 m
Landing distance	280 ft	85 m
Service Ceiling	15000 ft	4500 m
Fuel Consumption		9 l/h
Engine		
Max Power (6200 rpm – 3 min)	60 hp	44 kW
Max continuous Power (5800 rpm)	56 hp	41 kW

*Specifications may change during the final design.*

Designed by:  
Dr. James Waterhouse james@aeroalcool.com.br  
Aeroálcool Tecnologia Ltda.  
Rod. Franca/Batatais, SP-336, Km 2,  
Aeroporto Estadual de Franca, Franca, SP, Brazil  
Tel: +55 16 3701 7894

**aeroálcool**  
www.aeroalcool.com.br

USA exclusive distributor:  
Frank Porter [flybuy1@comcast.net](mailto:flybuy1@comcast.net)  
Quasar Aircraft Company, LLC  
[www.quasaircraft.com](http://www.quasaircraft.com)  
2273 SE 10th St, Pompano Beach, FL 33062  
Tel: 954-788-6660/Fax:954-788-6760/  
Cell:954-675-8436